

Surface Mount Schottky Barrier Rectifier

Features

- The plastic package carries Underwriters Laboratory Flammability Classification 94V-0
- For surface mounted applications
- Metal silicon junction, majority carrier conduction
- Low power loss, high efficiency
- Built-in strain relief, ideal for automated placement
- High forward surge current capability
- Lead free in comply with EU RoHS 2011/65/EU directives

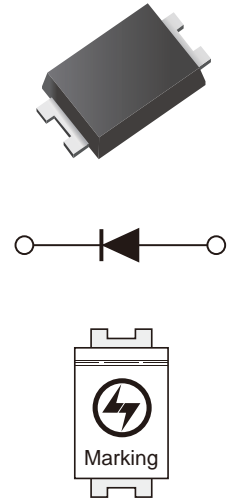

Mechanical Data

- Case: PDFN3620
- Terminal: Leads solderable per MIL-STD-750 Method 2026
- Polarity: Color band denotes cathode end
- Mounting Position: Any

Ordering Information

Part Number	Shipping	Reel
LT32P3 THRU LT320P3	12000PCS Tape&Reel	13 inches

Maximum Ratings and Electrical Characteristics

Ratings at 25°C ambient temperature unless otherwise specified.
 Single phase half-wave 60Hz, resistive or inductive load, for capacitive load current derate by 20%.

Parameter	Symbol	LT32P3	LT34P3	LT36P3	LT38P3	LT310P3	LT315P3	LT320P3	Unit
	Marking	P32	P34	P36	P38	P310	P315	P320	
Maximum repetitive peak reverse voltage	V_{RRM}	20	40	60	80	100	150	200	V
Maximum RMS voltage	V_{RMS}	14	28	42	56	70	105	140	V
Maximum DC blocking voltage	V_{DC}	20	40	60	80	100	150	200	V
Maximum instantaneous forward voltage at 3A	V_F	0.5	0.5	0.7	0.85	0.85	0.95	0.95	V
Maximum average forward rectified current at T_L (see fig.1)	$I_{(AV)}$	3							A
Peak forward surge current 8.3ms single half sine-wave superimposed on rated load (JEDEC Method)	I_{FSM}	80							A
Maximum DC reverse current $T_A=25^\circ\text{C}$ at rated DC blocking voltage $T_A=100^\circ\text{C}$	I_R	0.5				0.2		2	mA
		20			10				
Typical Junction Capacitance (Note1)	C_J	500			300				pF
Typical thermal resistance (Note2)	$R_{\theta JA}$	55							$^\circ\text{C}/\text{W}$
Operating junction temperature range	T_J	-55 to +150							$^\circ\text{C}$
Storage temperature range	T_{STG}	-55 to +150							$^\circ\text{C}$

Note:(1) Measured at 1MHz and applied reverse voltage of 4.0V D.C.

(2) P.C.B. mounted with 2.0" x 2.0"(5.0cm x 5.0cm) copper pad areas.



Characteristics Curve

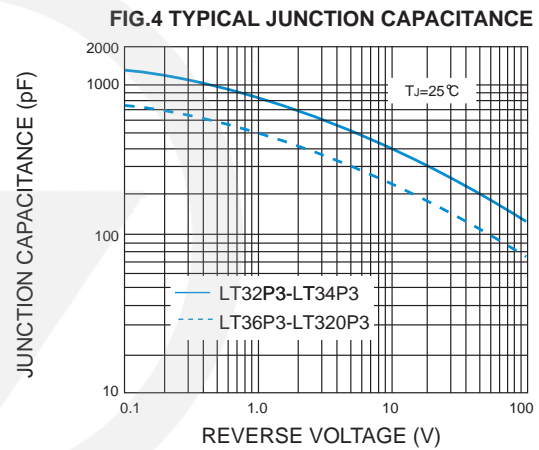
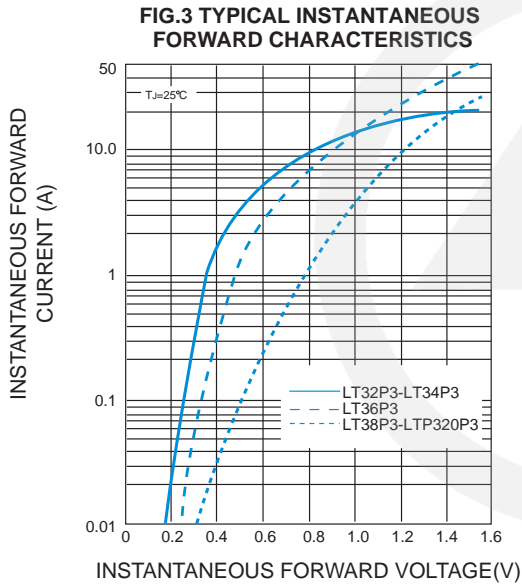
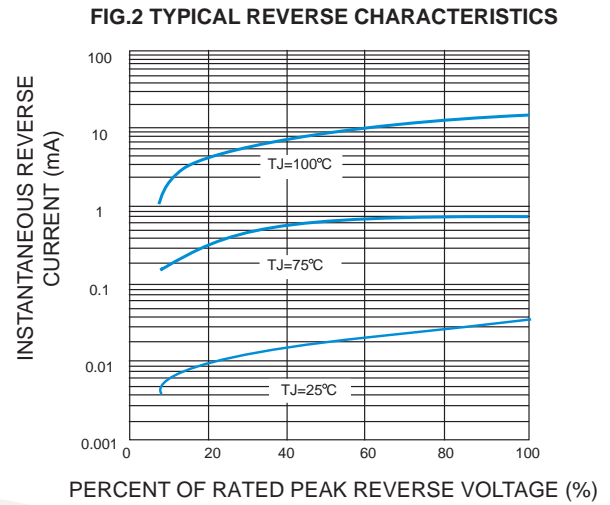
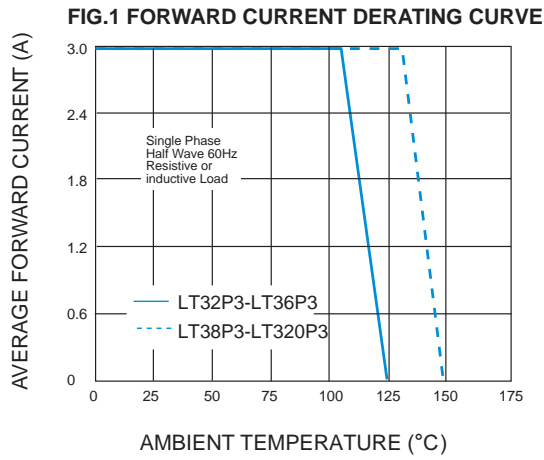

FIG.5 MAXIMUM NON-REPETITIVE PEAK FORWARD SURGE CURRENT

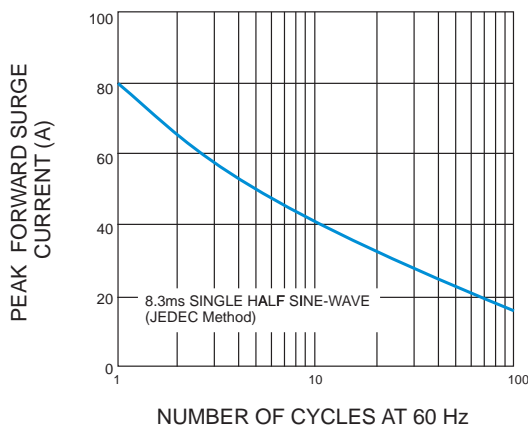
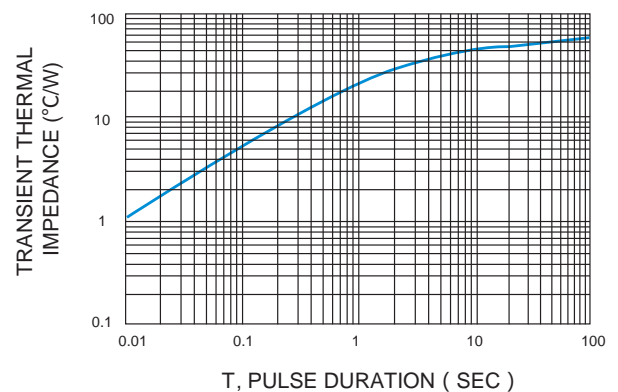

FIG.6 TYPICAL TRANSIENT THERMAL IMPEDANCE



Package Outline

PDFN3620

Unit : mm

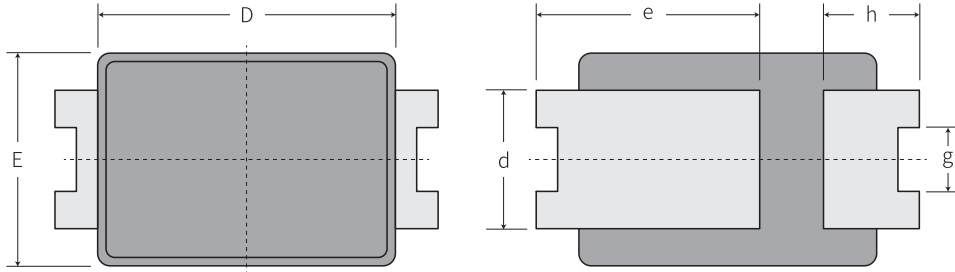

Top View

Bottom View

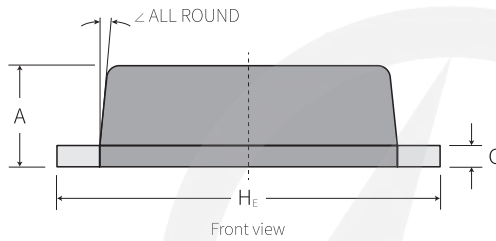

Front view

UNIT		A	C	D	E	H _E	d	e	g	h	∠
mm	max	1.15	0.30	3.00	2.20	3.80	1.50	2.30	0.80	1.10	6°
	min	0.75	0.10	2.60	1.80	3.40	1.10	1.70	0.40	0.70	

Suggested Pad Layout

PDFN3620

Unit : mm

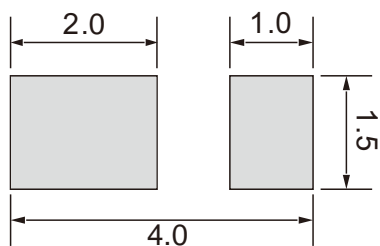

Note:

1. Controlling dimension: in millimeters.
2. General tolerance: ± 0.05 mm
3. The pad layout is for reference purpose only.

Carrier Tape Dimensions

Unit : mm

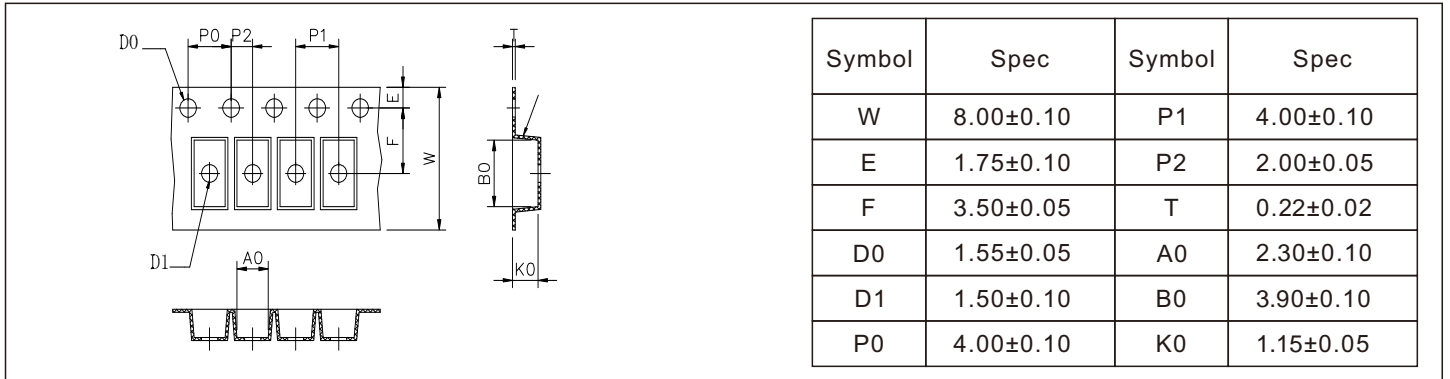

Reel Dimensions

Unit : mm

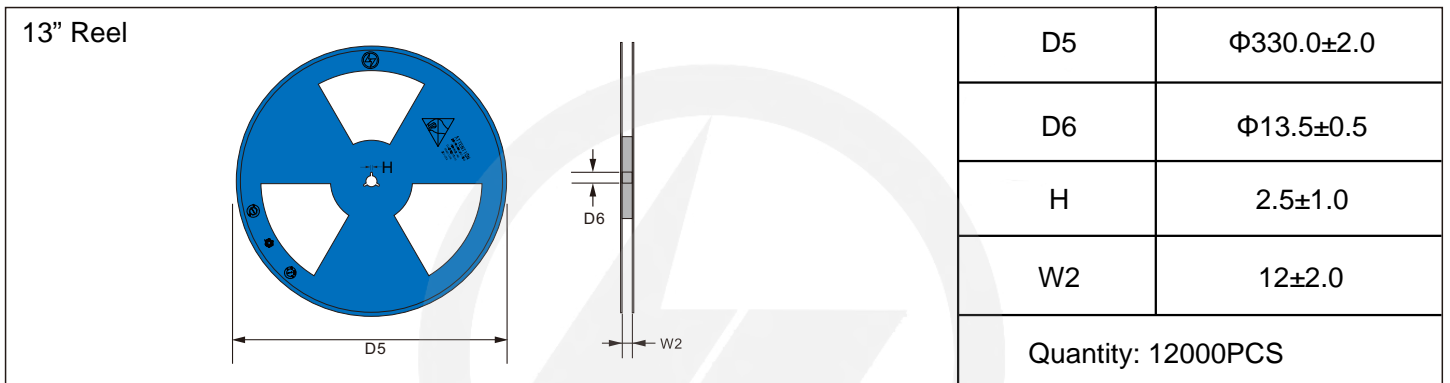

Packaging

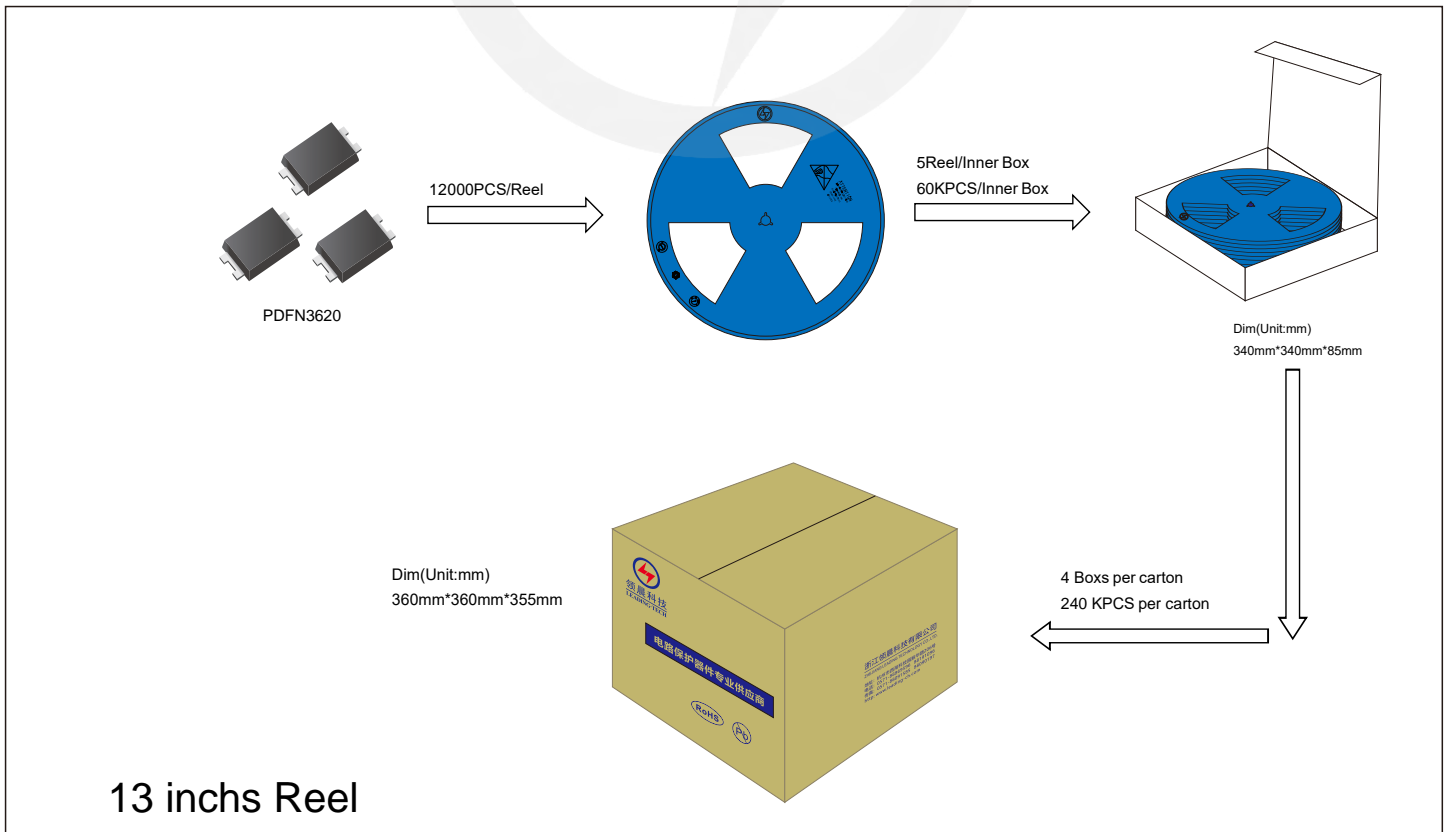



Recommended Soldering Conditions

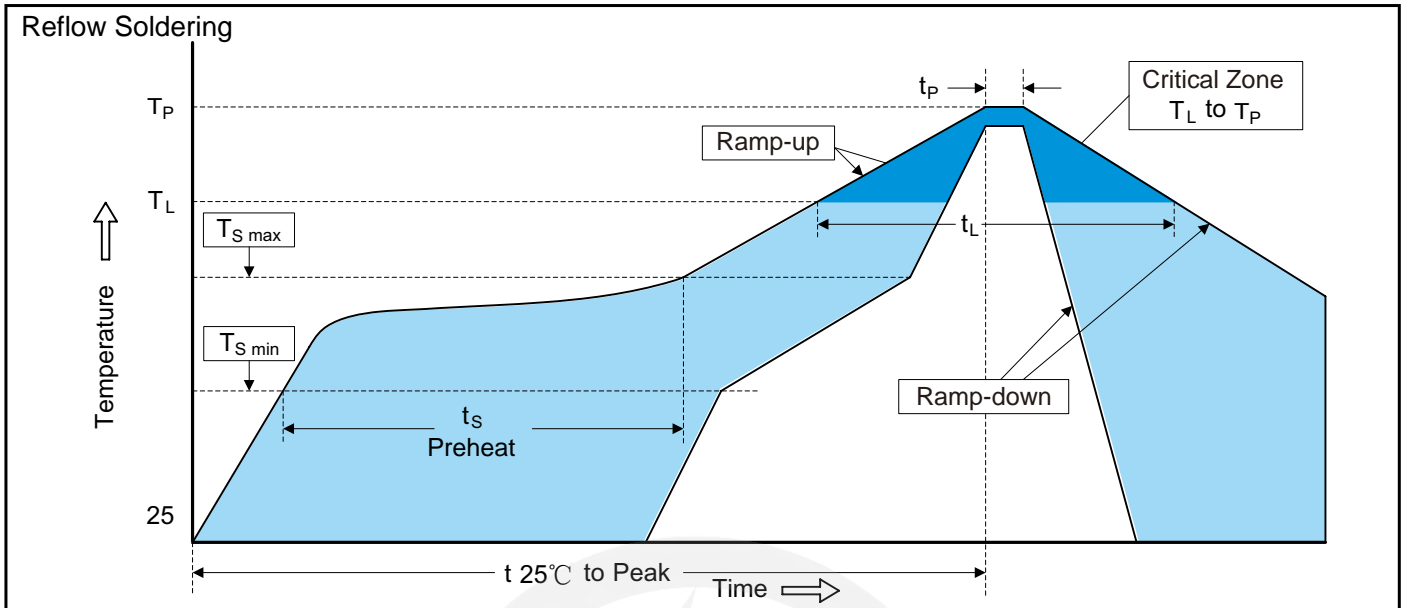

Recommended Conditions

Profile Feature	Pb-Free Assembly
Average ramp-up rate (T _L to T _P)	3°C/second max.
Preheat	
-Temperature Min (T _{S min})	150°C
-Temperature Max (T _{S max})	200°C
-Time (min to max) (t _s)	60-180 seconds
T _{S max} to T _L	
-Ramp-up Rate	3°C/second max.
Time maintained above:	
-Temperature (T _L)	217°C
-Time (t _L)	60-150 seconds
Peak Temperature (T _P)	260°C
Time within 5°C of actual Peak Temperature (t _p)	20-40 seconds
Ramp-down Rate	6°C/second max.
Time 25°C to Peak Temperature	8 minutes max.

Important Notice and Disclaimer

Leading-Tech reserves the right to make changes to this document and its products and specifications at any time without notice.

Customers should obtain and confirm the latest product information and specifications before final design, purchase or use.

Leading-Tech makes no warranty, representation or guarantee regarding the suitability of its products for any particular purpose, not does Leading-Tech assume any liability for application assistance or customer product design.

Leading-tech does not warrant or accept any liability with products which are purchase or used for any unintended or unauthorized application.

No license is granted by implication or otherwise under any intellectual property rights of Leading-Tech.

Leading-Tech products are not authorized for use as critical components in life support devices or systems without express written approval of Leading-tech.

Version Update Information

Series NO.	Enactment/Revision Date	Effective Date	Version	Revision content	Revision Reason	Revision Person	Note
01	2024.03.01	2024.03.01	1.0	New File	/	Ding	
02	2025.04.18	2025.04.18	1.1	1.Revise Marking 2.Package Outline e(min)=1.7	/	Ding	
03	2025.06.30	2025.06.30	1.2	Update packagin information	/	Ding	